



XM-7613

SEATED CALF RAISE

Owner's Manual

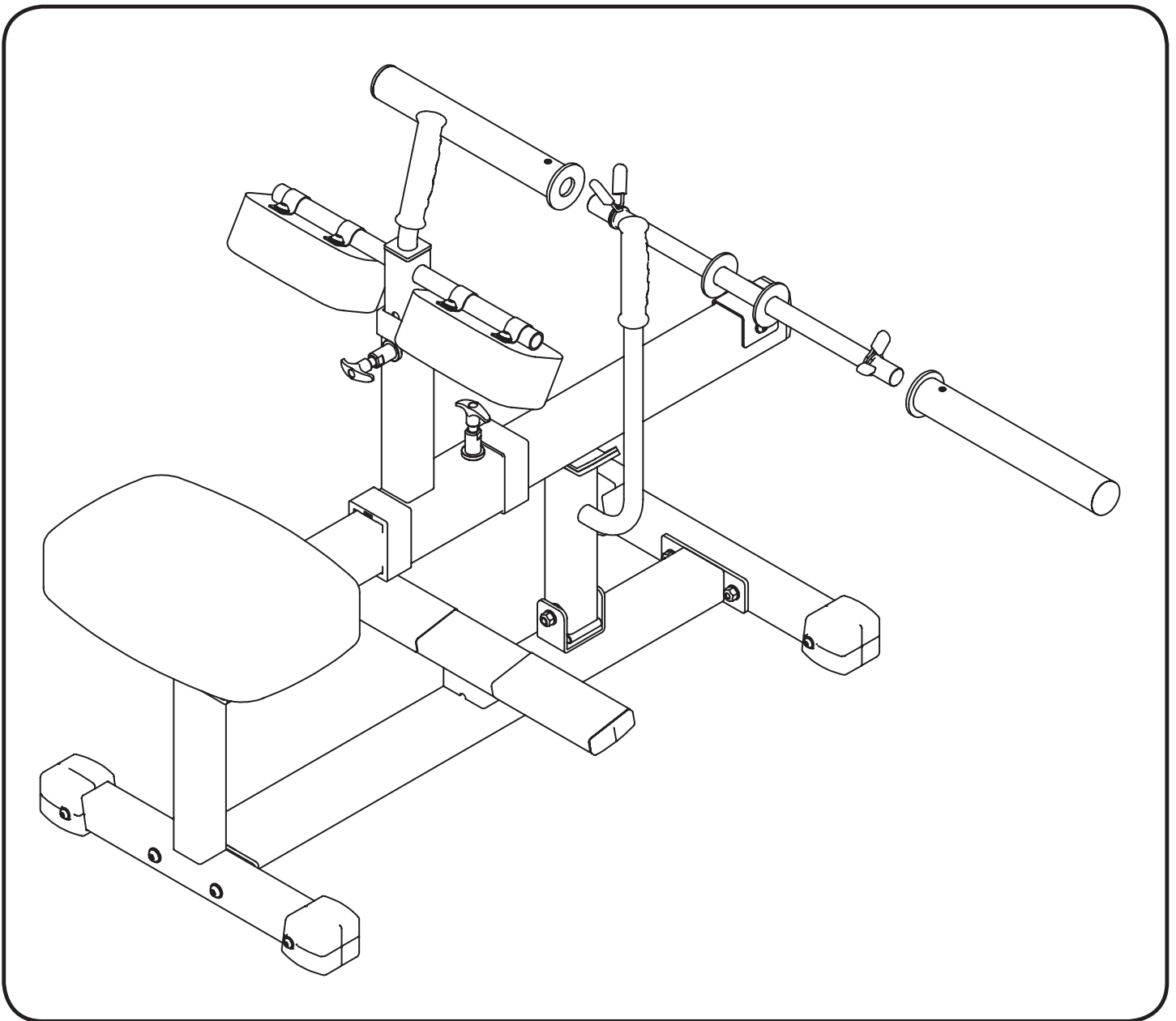

Table of Contents



Important Safety Information	3
Before You Start	4
Assembly	5 - 8
Parts List	9
Exploded View	10
Warranty Information	11

NOTE: Hand tighten bolts and nylon nuts until machine is fully assembled.

Prior to assembly, remove components from the box and verify that all the listed parts were supplied.

SAFETY INFORMATION WARNING!

Before using this unit or starting any exercise program, consult your physician. This is especially important for persons over the age of 35 and/or persons with pre-existing health problems. XMARK Fitness assumes no responsibility for personal injury or property damage sustained by or through the use of this product.

It is the owner's responsibility to ensure that all users of this unit have read the Owner's Manual and are familiar with safety information and precautions.

SAFETY PRECAUTIONS

- This unit should only be used on a level surface and is intended for indoor use only. XMARK Fitness recommends an equipment mat be placed under the unit to protect the floor or carpet and for easier cleaning.
- Wear comfortable, good-quality walking or running shoes and appropriate clothing. Do not use this unit with bare feet, sandals, socks or stockings!
- Always examine your unit before using to ensure all parts are in working order.
- Do not leave children unsupervised near or on the unit.
- Service to your unit should only be performed by an authorized service representative, unless authorized and/or instructed by a XMARK Fitness technician. Failure to follow these instructions will void the warranty.

Before You Start



THANK YOU for making this unit a part of your exercise program. XMARK Fitness assures the very best in value, appearance, durability and biomechanics.

This manual will guide you through the assembly process. If at any time you are having trouble with the assembly or use of this product, then please contact us at our XMARK Fitness help line. We have trained service technicians on site to take care of you, our valued customer.

REGISTRATION CARD

To avoid unnecessary delays in warranty parts and to insure that a permanent record of your purchase is on file with our company, be sure to send in the warranty registration card or register online at www.xmarkfitness.com within 10 days of purchase.

MAILING ADDRESS

XMARK Fitness
7501 Trammel Drive
Shreveport, LA 71108

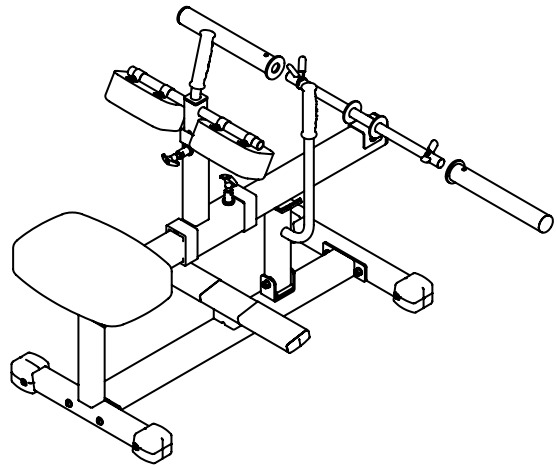

XMARK FITNESS SERIES
MODEL: XM-7613

**QUESTIONS?
CALL 1-800-719-4605**

**Monday-Friday
8:30 a.m.-5:00 p.m.**
(Central Standard Time)

When calling please have the following product information available:

Model Name :

Date Mfg.:

Serial #

Model Name Decal Location

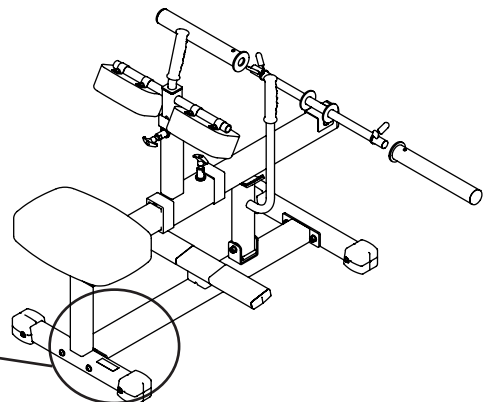

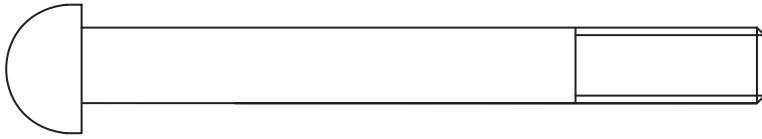

[30#] M10*90 1pc

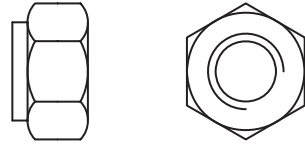

[32#] M10 7pcs

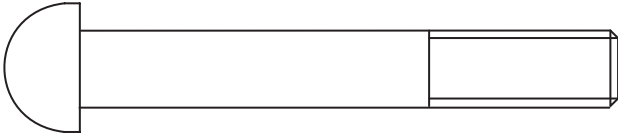

[29#] M10*70 5pcs

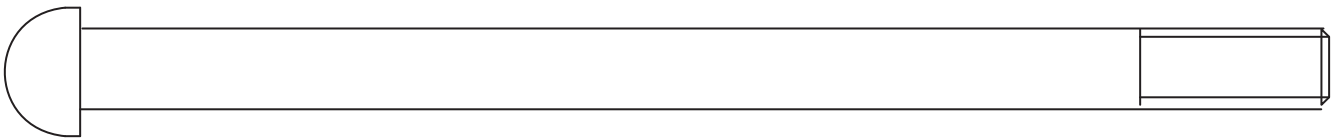

[31#] M10*165 1pc

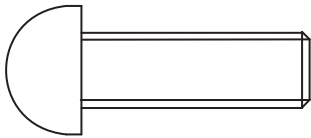

[28#] M10*30 10pcs

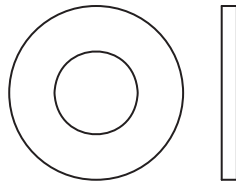

[27#] $\text{Ø} 9 * \text{Ø} 22 * 2$ 8 pcs

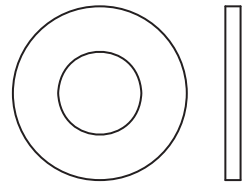

[33#] $\text{Ø} 11 * \text{Ø} 20 * 2$ 24pcs



Millimeters

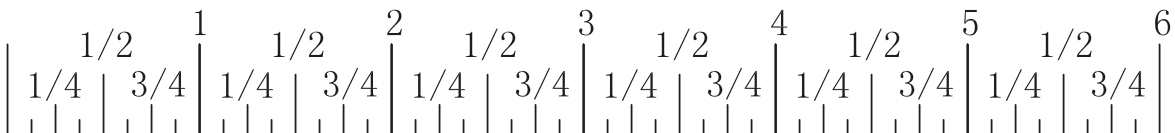

Inches

NOTE: Hand tighten bolts and Nylon Lock nuts until machine is fully assembled.

Step 1

Attach the Upright Rear (#2) to the Cross Base (#1) using:

- two M10*70 Button Head Cap Screws (#29)
- four $\Phi 11 * \Phi 20 * 2$ Flat Washers (#33)
- two M10 Nylon Lock Nuts (#32)

Attach the Front Base (#3) to the Cross Base (#1) using:

- two M10*70 Button Head Cap Screws (#29)
- four $\Phi 11 * \Phi 20 * 2$ Flat Washers (#33)
- two M10 Nylon Lock Nuts (#32)

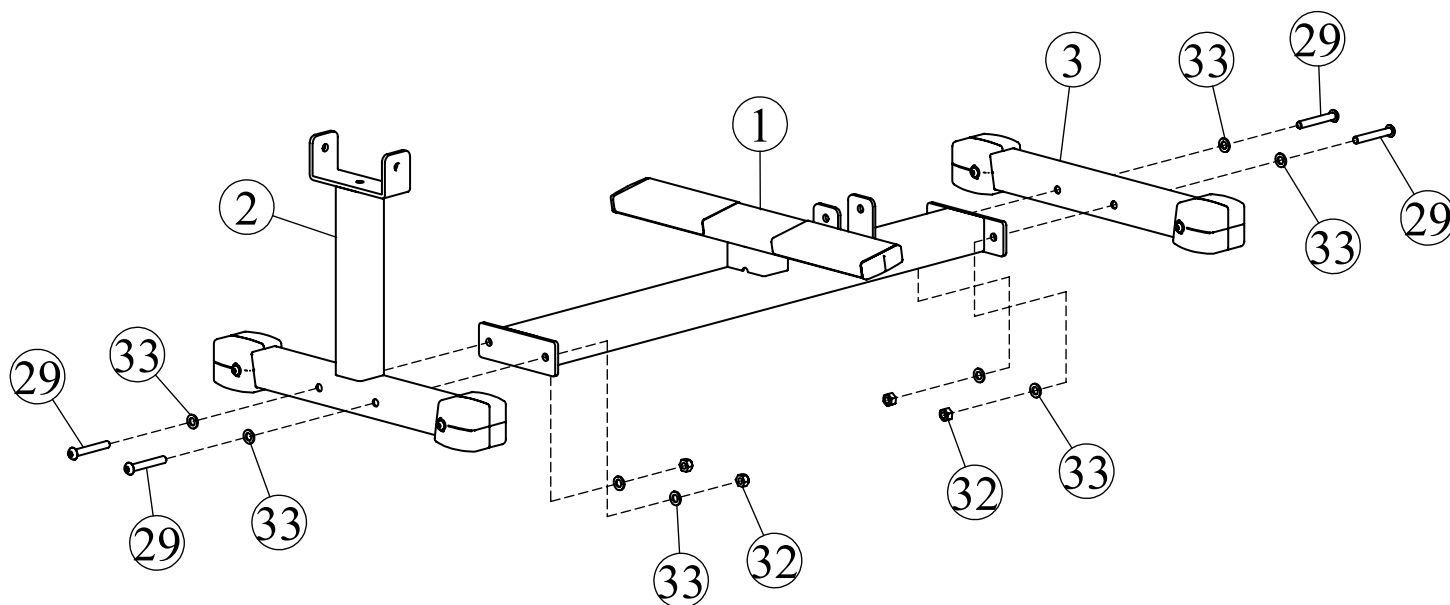

NOTE: Hand tighten bolts and Nylon Lock nuts until machine is fully assembled.

Step 2

Attach the Swing Frame (#4) to the Upright Rear (#2) using:

- one M10*165 Button Head Cap Screw (#31)
- two $\Phi 11*\Phi 20*2$ Flat Washes (#33)
- one M10 Nylon Lock Nut (#32)

Attach the Stopper Frame (#5) to Cross Base (#1) using:

- one M10*90 Button Head Cap Screw (#30)
- two $\Phi 11*\Phi 20*2$ Flat Washers (#33)
- one M10 Nylon Lock Nut (#32)

Attach the Adjustable Slide (#6) to the Swing Frame (#4).

Attach the Weight Holder (#9) to the Swing Frame (#4) using:

- one M10*70 Button Head Cap Screw (#29)
- two $\Phi 11*\Phi 20*2$ Flat Washers (#33)
- one M10 Nylon Lock Nut (#32)

Attach two Spring Clips (#12) or two Adapters (#39) to the Weight Holder (#9).

Insert the Adjustable Pad Frame (#7) into the Adjustable Slide (#6).

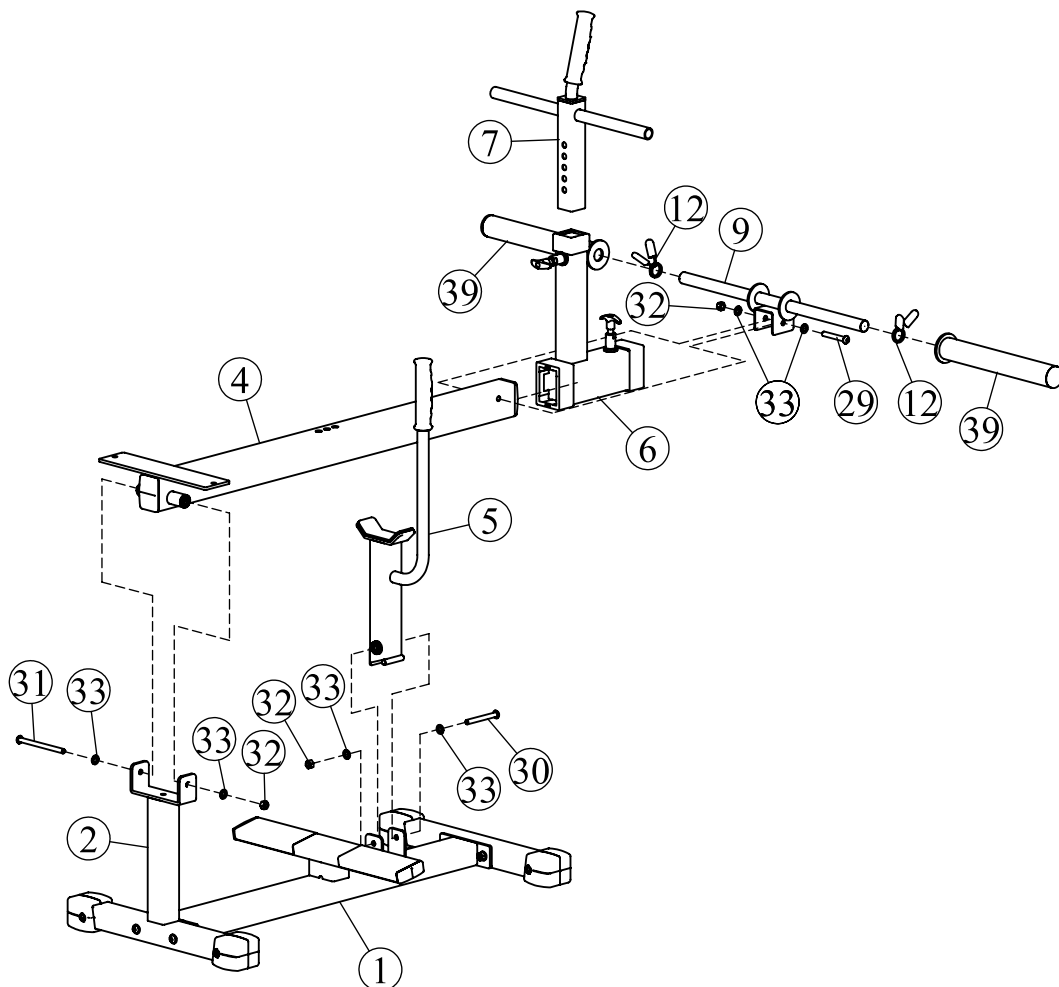

NOTE: Wrench tighten Bolts and Nylon Lock Nuts.

Step 3

Attach the Seat Pad (#26) to the Swing Frame (#4) using:

- two M10*30 Button Head Cap Screws (#28)
- two $\Phi 11 * \Phi 20 * 2$ Flat Washers (#33)

Attach two Knee Pad (#14) to the Adjustable Pad Frame (#7) using:

- four Brackets (#11)
- eight M10*30 Button Head Cap Screws (#28)
- eight $\Phi 11 * \Phi 20 * 2$ Flat Washers (#33)

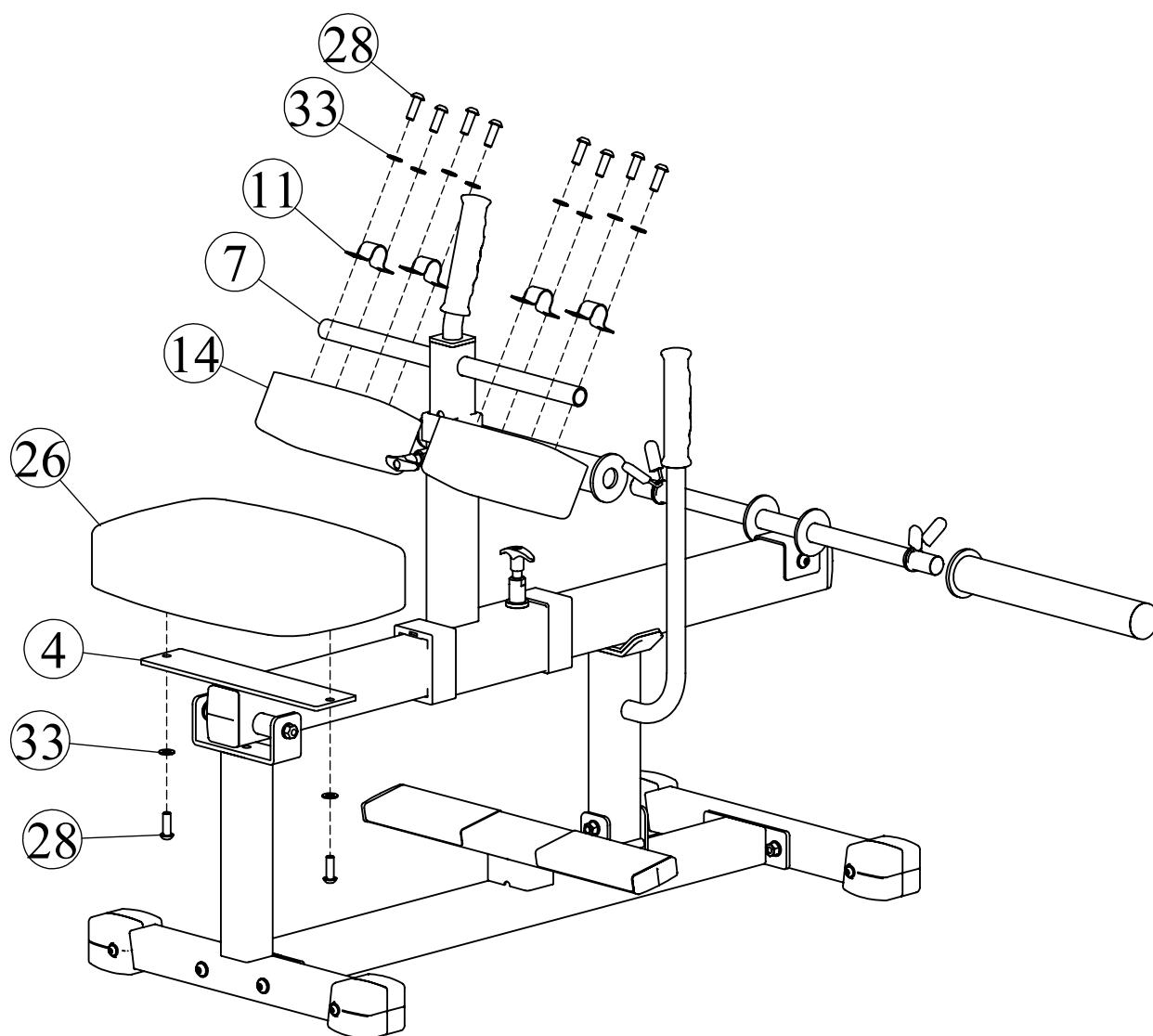

XM-7613 Parts List

Ref #	Part #	Description	Qty
1	P00397	Cross Base	1
2	P00231	Upright Rear	1
3	P00232	Front Base	1
4	P00398	Swing Frame	1
5	P00399	Stopper Frame	1
6	P00400	Adjustable Slide	1
7	P00401	Adjustable Pad Frame	1
8	P00663	Long Pop Pin XM Series	1
9	P00402	Weight Holder	1
10	P00574	Bronze Bushing	4
11	P00666	Bracket	4
12	P00570	Spring Clip	2
13	P00144	Plastic Sleeve, 63.5*88.9 - 50.8*76.2	2
14	P00068	Knee Pad XM Series	2
15	P00403	Long Sleeve Tube	1
16	P00153	Foot Cap, Right 50.8 XM Series	4
17	P00154	Foot Cap, Left 50.8 XM Series	4
18	P00233	Plug, 25.4*76.2	2
19	P00249	Plug, 50.8*76.2	2
20	P00416	Plastic Sleeve 50.8*44.5	1
21	P00201	Hand Grip	2
22	P00653	Spring Collar Plastic Grips	4
23	P00664	Pop Pin XM Series	1
24	P00008	Bumper	1
25	P00404	Non Slip Paper	2
26	P00069	Seat Pad XM Series	1
27	P00037	Flat Washer $\Phi 9 \times \Phi 22 \times 2$	8
28	P00599	Button Head Cap Screw M10*30	10
29	P00610	Button Head Cap Screw M10*70	5
30	P00615	Button Head Cap Screw M10*90	1
31	P00595	Button Head Cap Screw M10*165	1
32	P00561	Nylon lock Nut M10	7
33	P00134	Flat Washer $\Phi 11 \times \Phi 20 \times 2$	24
34	P00405	Short Sleeve Tube	1
35	P00636	Button Head Cap Screw M8*25	8
36	P00022	Wrench 17-19	1
37	P00560	Hex Key S6	1
39	P00644	Adapter	2
40	P00566	Plug 48	2
41	P00121	Screw M8*12	2
42	P00559	Hex Key S4	1
#	H00018	Bolt Pack, XM-7613	1
	M00022	Owner's Manual XM-7613	1



XMARK Fitness

7501 Trammel Drive

Shreveport, LA 71108

Customer Service: 1-800-719-4605